

AMP-05 - LABORATÓRIO DE ELETRICIDADE E ELETRÔNICA - PLANTA

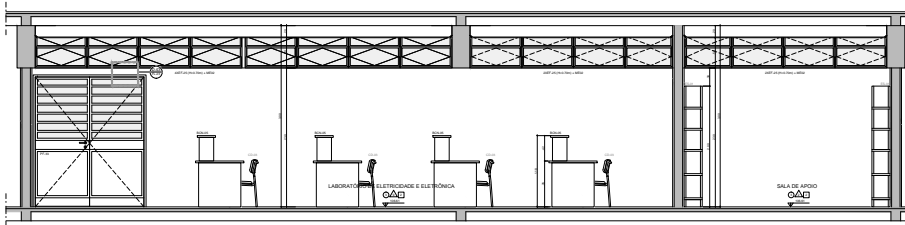

AMP-05 - LABORATÓRIO DE ELETRICIDADE E ELETRÔNICA - VISTA 01

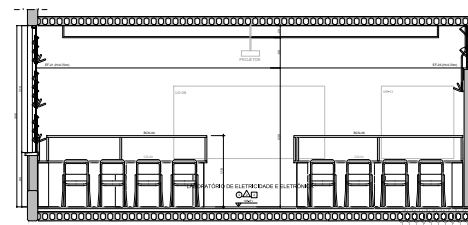

AMP-05 - LABORATÓRIO DE ELETRICIDADE E ELETRÔNICA - VISTA 04

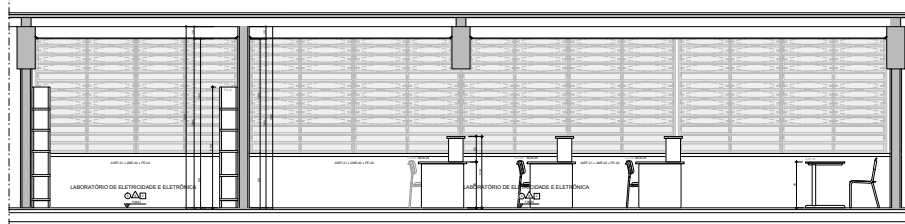

AMP-05 - LABORATÓRIO DE ELETRICIDADE E ELETRÔNICA - VISTA 03

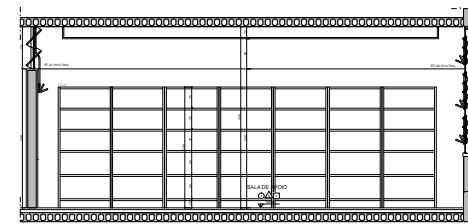

AMP-05 - LABORATÓRIO DE ELETRICIDADE E ELETRÔNICA - VISTA 02



PROPOSTOR	PROJETADE	PROJETO	TABELA DE ACRÓNIOS	LEGENDA	PROPOSTOR	PROJETADE	PROJETO	TABELA DE ACRÓNIOS	LEGENDA	PROPOSTOR	PROJETADE	PROJETO	TABELA DE ACRÓNIOS	LEGENDA

Autenticado com senha por SONIA ATSUKO GOTO SUGAHARA - Coordenador de Projeto / UIE/DE/DP - 13/06/2022 às 14:49:54.
 Documento Nº: 44355301-7012 - consulta à autenticidade em <https://www.documentos.spsempapel.sp.gov.br/sigaex/public/app/autenticar?n=44355301-7012>



CEETEPSCAP2022249024A

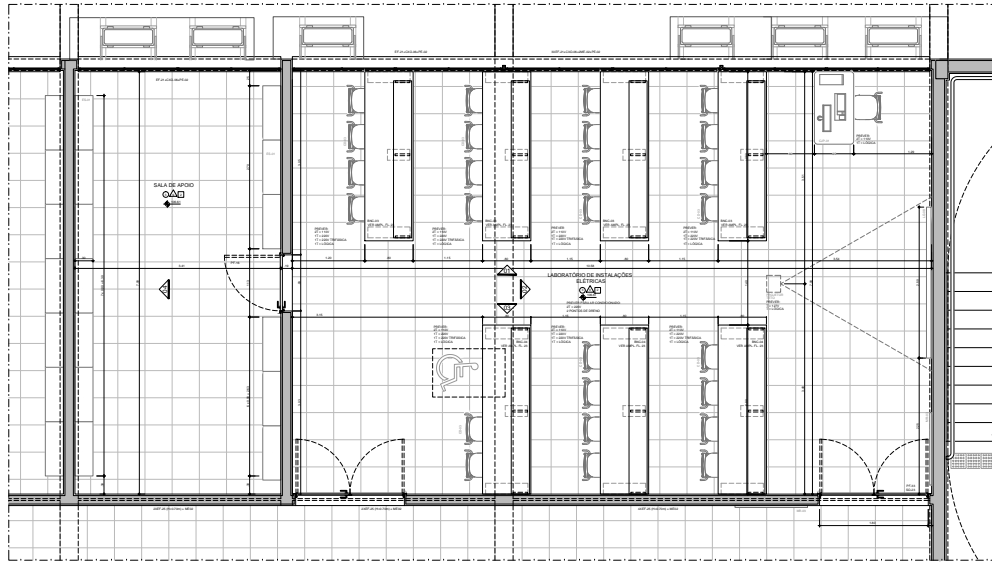

AMP-07 - LABORATÓRIO DE INSTALAÇÕES ELÉTRICAS - PLANTA

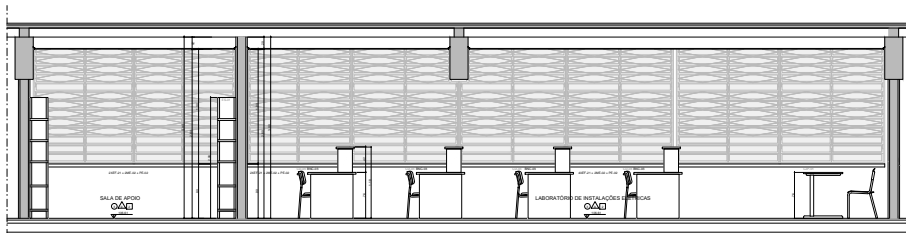

AMP-08 - LABORATÓRIO DE INSTALAÇÕES ELÉTRICAS - VISTA 01

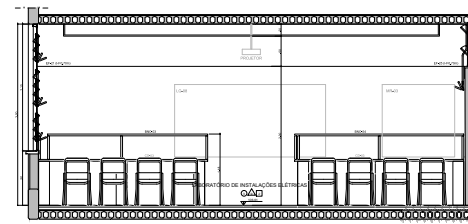

AMP-09 - LABORATÓRIO DE INSTALAÇÕES ELÉTRICAS - VISTA 02

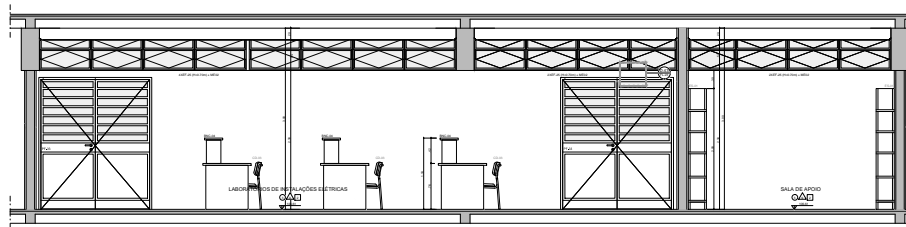

AMP-09 - LABORATÓRIO DE INSTALAÇÕES ELÉTRICAS - VISTA 03

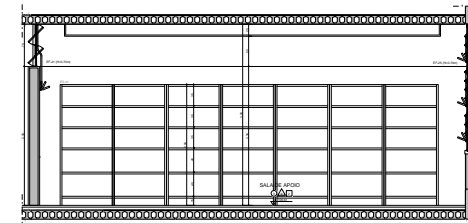

AMP-08 - LABORATÓRIO DE INSTALAÇÕES ELÉTRICAS - VISTA 04



PROPOSTOR	PROJETADE	TABELA DE ACRÓNIAMOS	LEGENDAS	PROJETO

FUNDAÇÃO PARA O DESENVOLVIMENTO DA EDUCAÇÃO - FDE
 INSTITUTO DE FÍSICA DE SÃO CARLOS - IFSC
 INSTITUTO DE FÍSICA DE RORAIMA - IFRR
 TERRENO TABOÃO (L.E. TABOÃO DA BERRA)

Autenticado com senha por SONIA ATSUKO GOTO SUGAHARA - Coordenador de Projeto / UIE/DE/DP - 13/06/2022 às 14:49:54.
 Documento Nº: 44355301-7012 - consulta à autenticidade em <https://www.documentos.spsempapel.sp.gov.br/sigaex/public/app/autenticar?n=44355301-7012>



CEETEPSCAP2022249024A

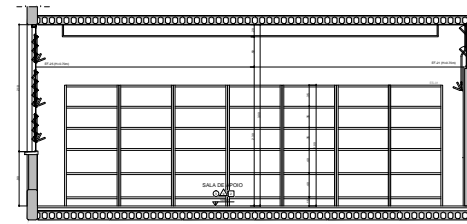
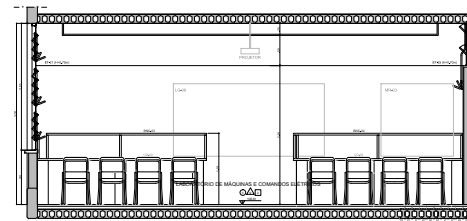
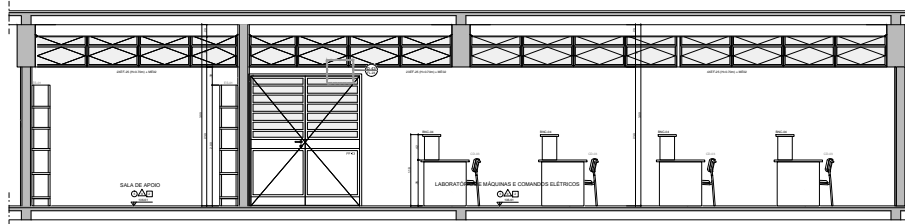
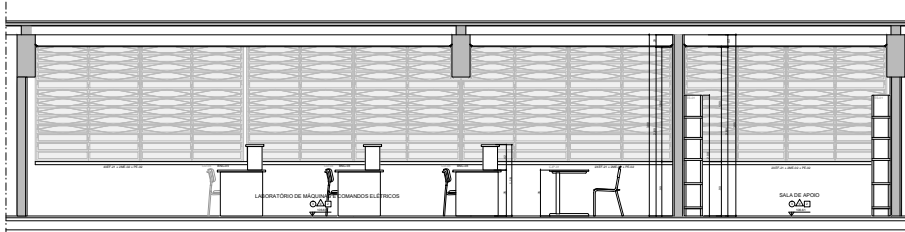
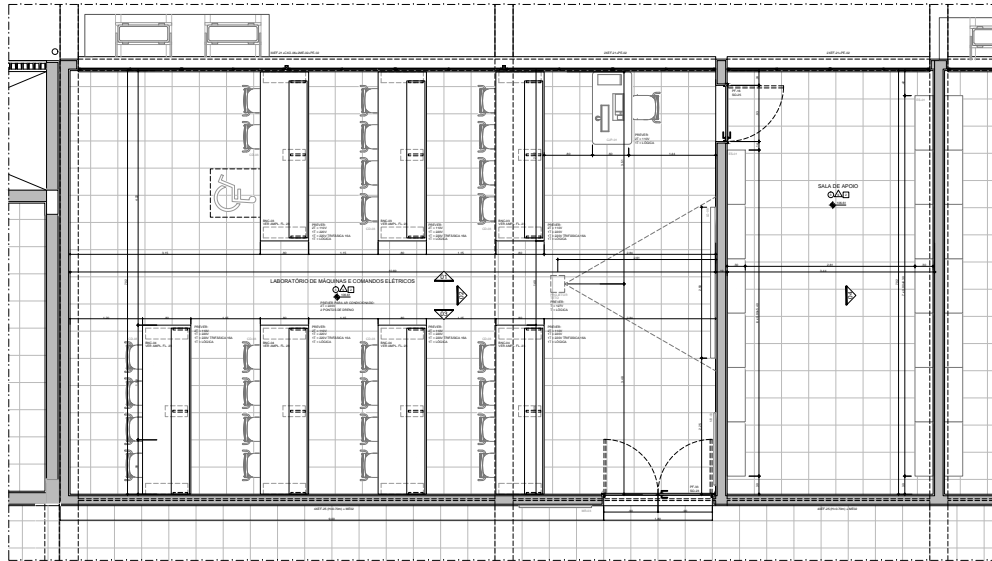

PROPOSTOR	PROJETADE	TÍTULO	TIPO	LEGENDA	ESCALA	FECHA

FUNDAÇÃO PARA O DESENVOLVIMENTO DA EDUCAÇÃO - FDE
 TERRENO TABOÃO II E TABOÃO DA BERRA



CEETEPSCAP2022249024A

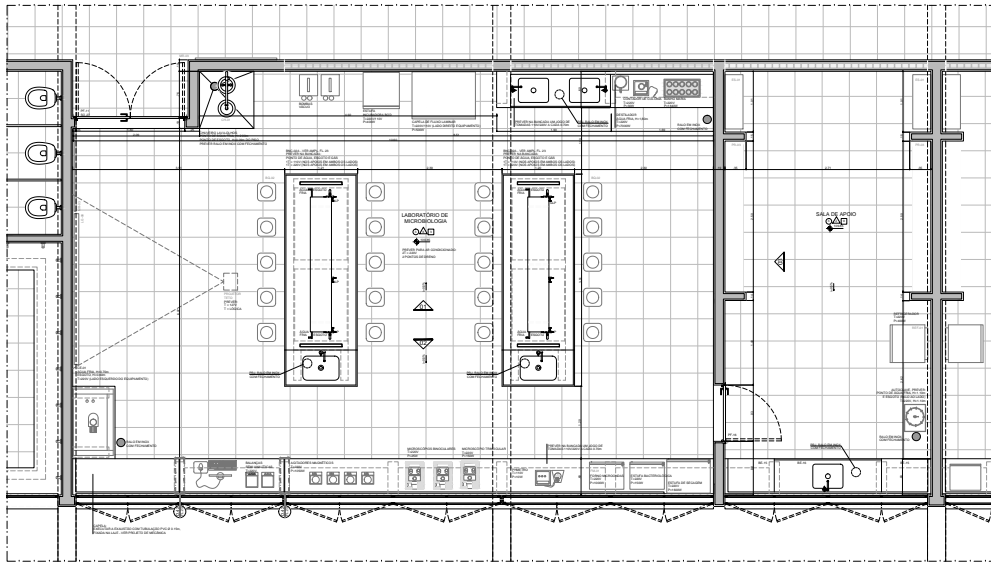

AMP-09 - LABORATÓRIO DE MICROBIOLOGIA | PLANTA

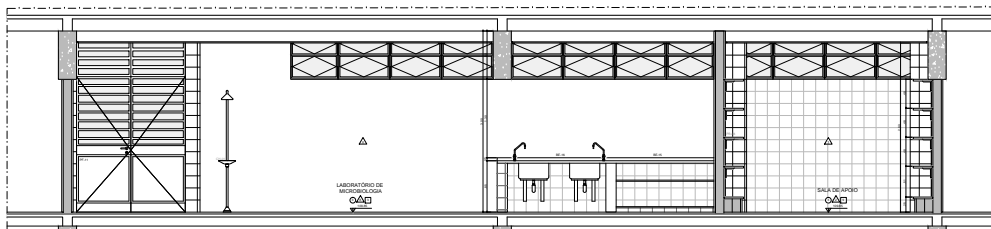

AMP-09 - LABORATÓRIO DE MICROBIOLOGIA | ELEVÇÃO 1

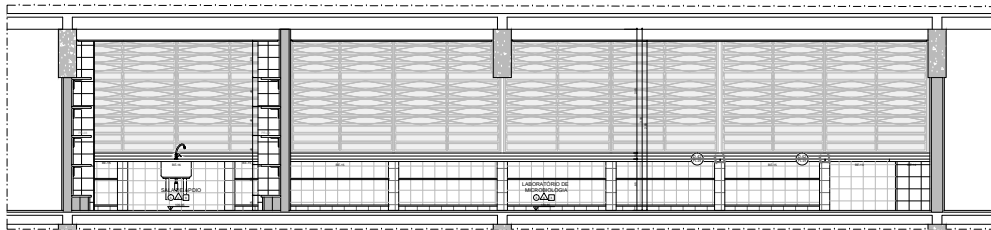

AMP-09 - LABORATÓRIO DE MICROBIOLOGIA | ELEVÇÃO 2

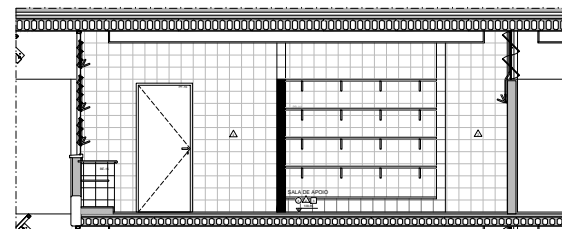

AMP-09 - LABORATÓRIO DE MICROBIOLOGIA | ELEVÇÃO 3



PROFESSOR	PROFESSOR	TABELA DE ACOMODADOS	PROFESSOR	LEGENDA



FABRICAÇÃO PARA O DESENVOLVIMENTO DA EDUCAÇÃO - FDE
 TERRENO TABOÃO II E TABOÃO DA BERRA

Autenticado com senha por SONIA ATSUKO GOTO SUGAHARA - Coordenador de Projeto / UIE/DE/DP - 13/06/2022 às 14:49:54.
 Documento Nº: 44355301-7012 - consulta à autenticidade em <https://www.documentos.spsempapel.sp.gov.br/sigaex/public/app/autenticar?n=44355301-7012>



CEETEPSCAP20222490244

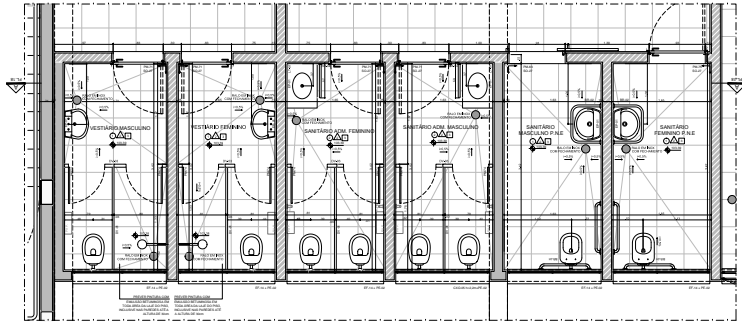

AMP 09 - CNUT. SANITÁRIOS 1º PVTO

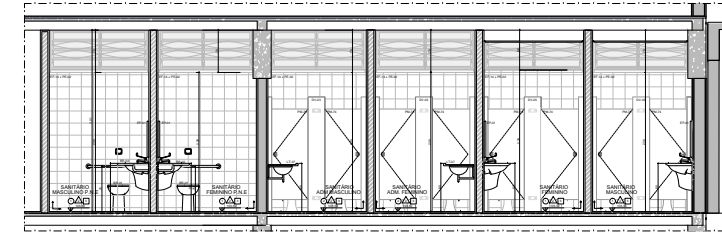

AMP 09 - CNUT. SANITÁRIOS 1º PVTO - CORTE AA

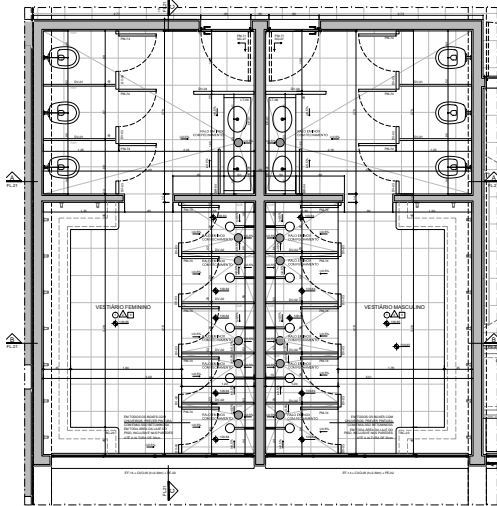

AMP 11 - VESTIÁRIOS 3º PVTO

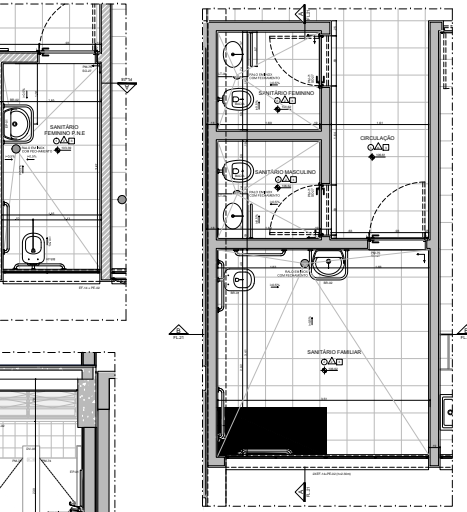

AMP 10 - CNUT. SANITÁRIOS 2º PVTO

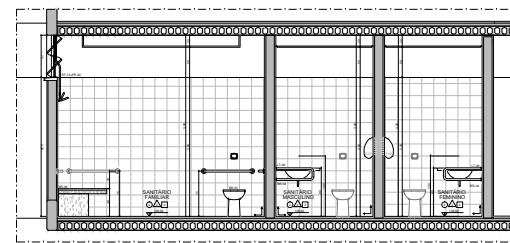

AMP 10 - CNUT. SANITÁRIOS 2º PVTO - CORTE AA

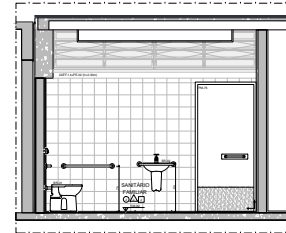

AMP 10 - CNUT. SANITÁRIOS 2º PVTO - CORTE BB

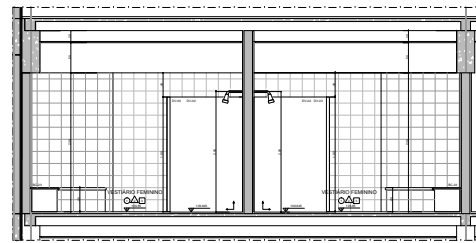

AMP 11 - VESTIÁRIOS 3º PVTO - CORTE BB

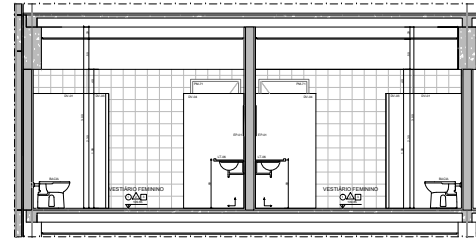

AMP 11 - VESTIÁRIOS 3º PVTO - CORTE AA

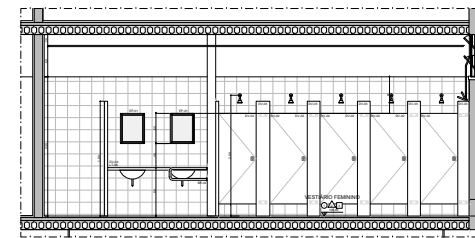

AMP 11 - VESTIÁRIOS 3º PVTO - CORTE CC



PROFESSOR	TÍTULO	TABELA DE ACRÉSCIMOS	EMP	LEGENDA	PROPOSTA DE PROJETO	PROPOSTA DE PROJETO	PROPOSTA DE PROJETO	PROPOSTA DE PROJETO	PROPOSTA DE PROJETO



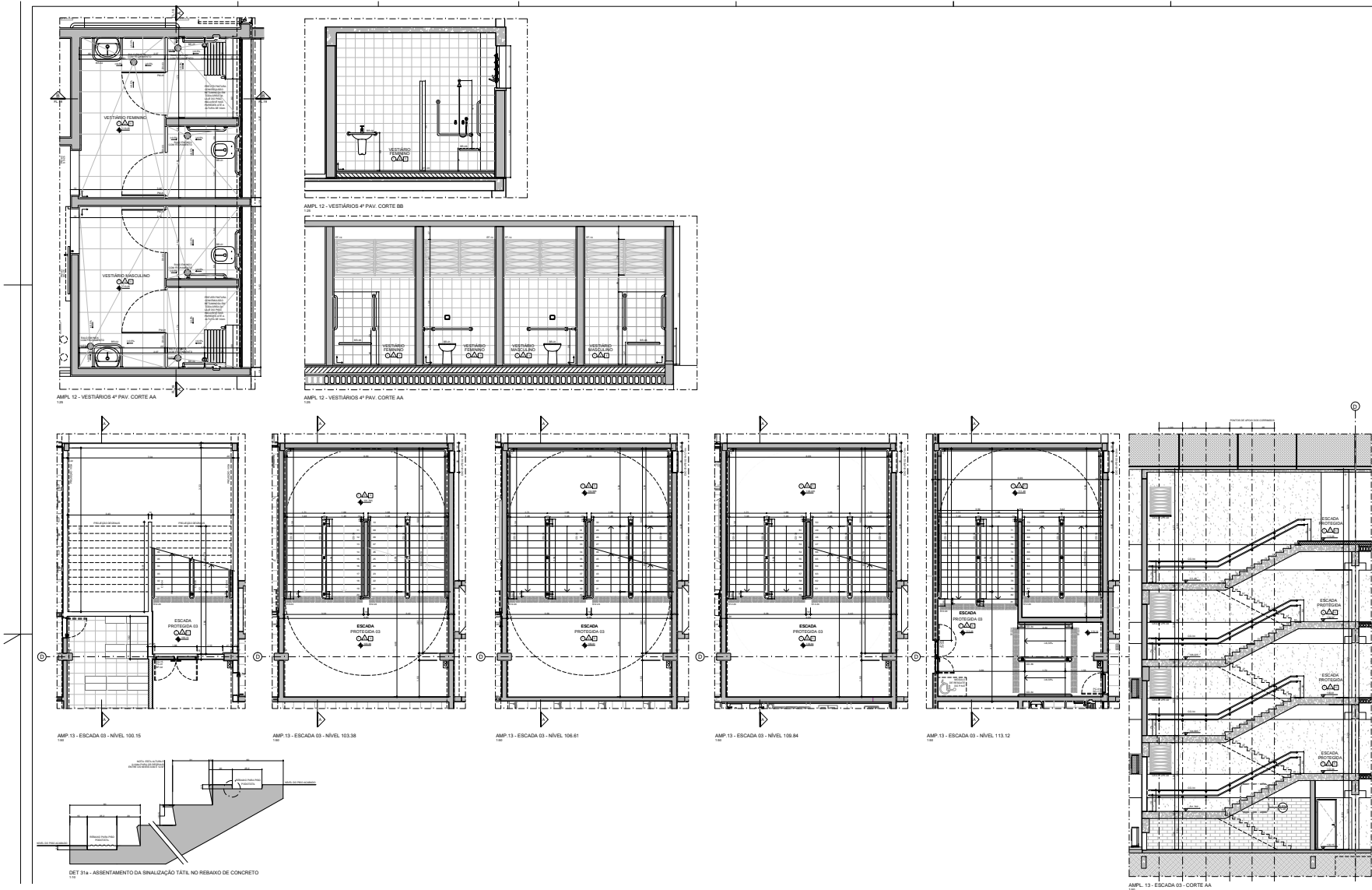

PROFESSOR	PROJETO	TABELA DE ACABAMENTOS	LEGENDA	PROJETO	PROJETO	PROJETO	PROJETO	PROJETO	PROJETO	PROJETO	PROJETO	PROJETO	PROJETO

Autenticado com senha por SONIA ATSUKO GOTO SUGAHARA - Coordenador de Projeto / UIE/DE/DP - 13/06/2022 às 14:49:54.
Documento N°: 44355301-7012 - consulta à autenticidade em <https://www.documentos.spsempapel.sp.gov.br/signaex/public/app/autenticar?n=44355301-7012>



CEETPSCAP2022249024A

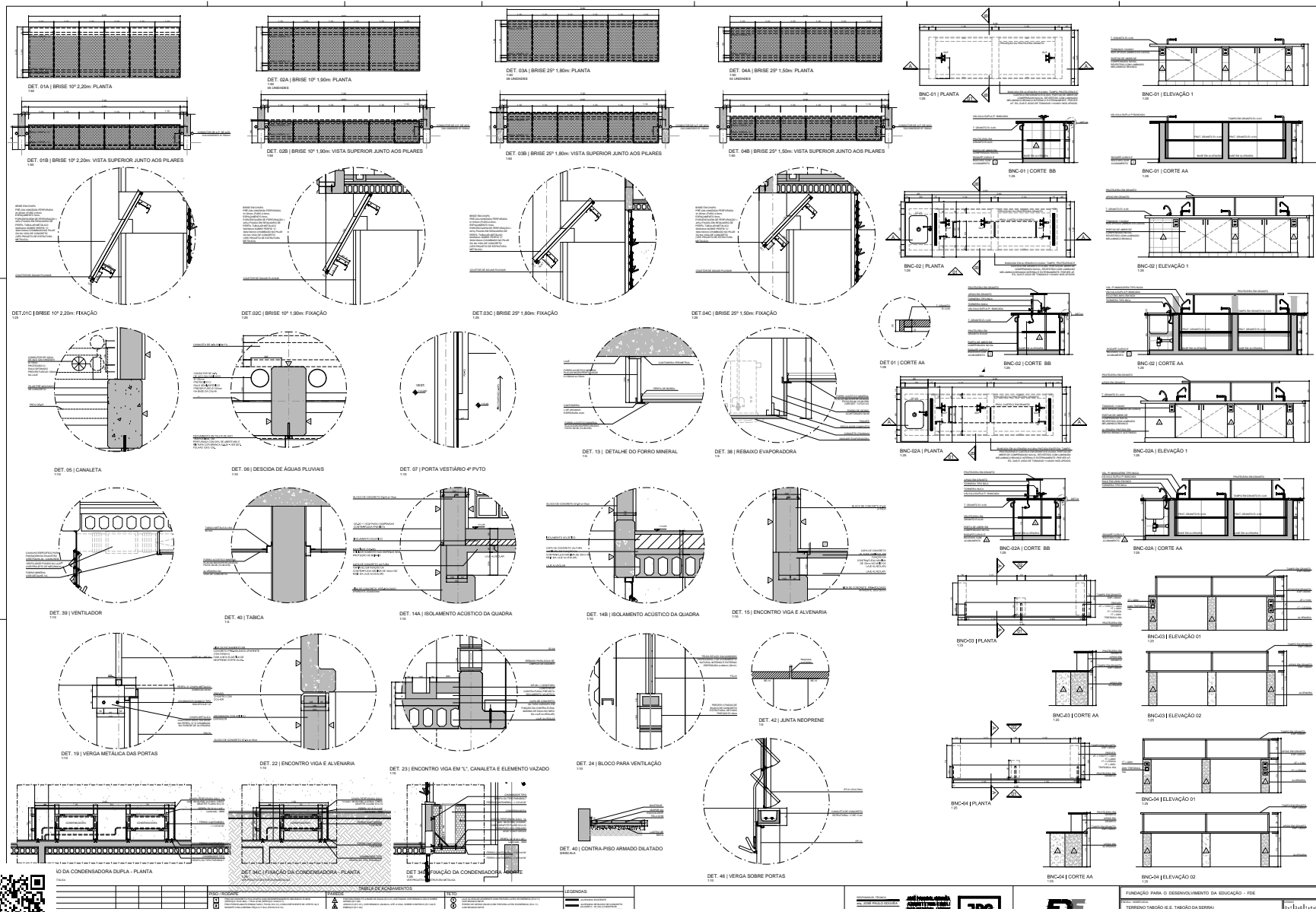

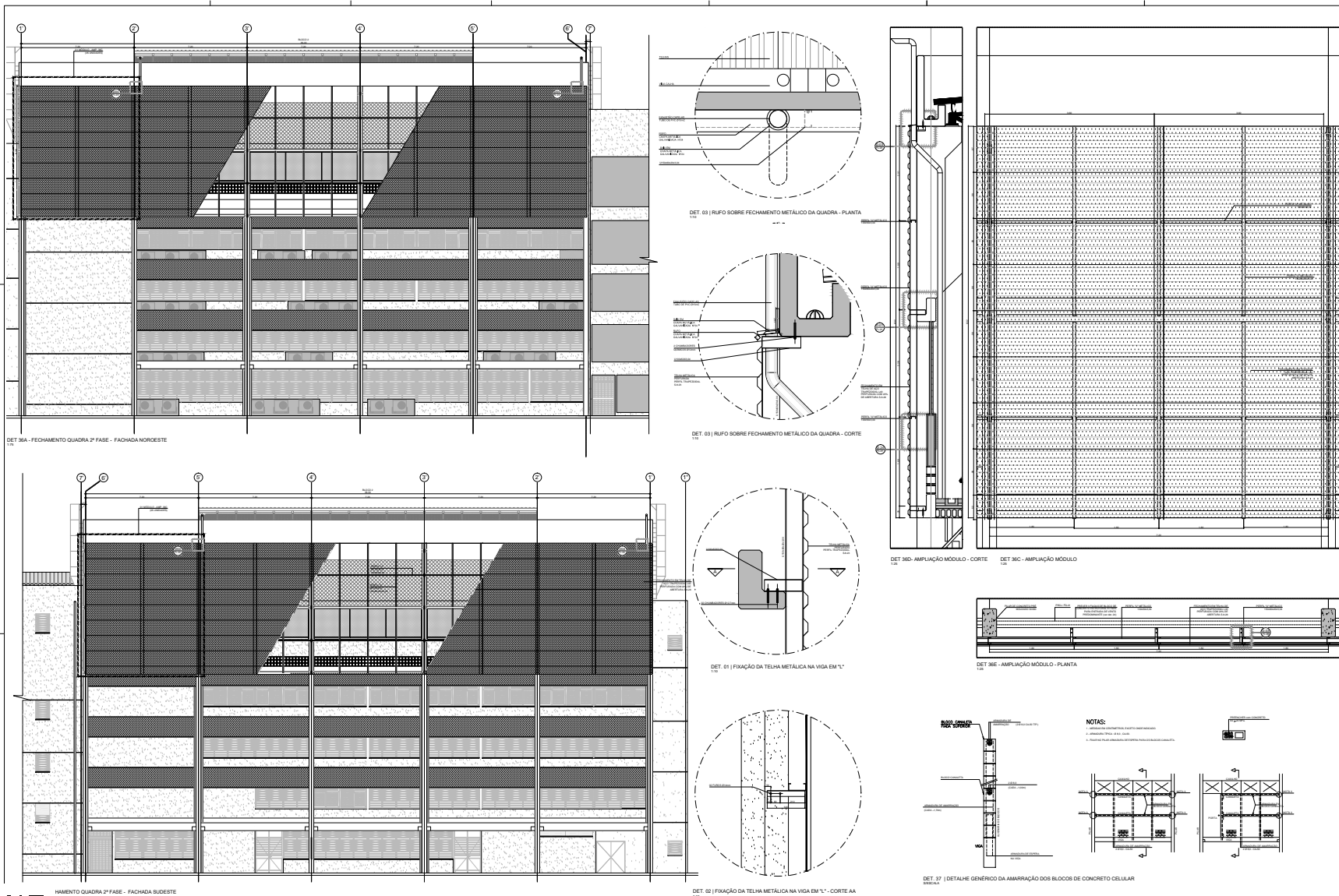

PROPOSTOR	PROJETA	TABELA DE ACRÉSCIMOS	LEGENDA	PROJETO	PROPOSTOR	PROJETA	PROPOSTOR	PROJETA	PROPOSTOR	PROJETA

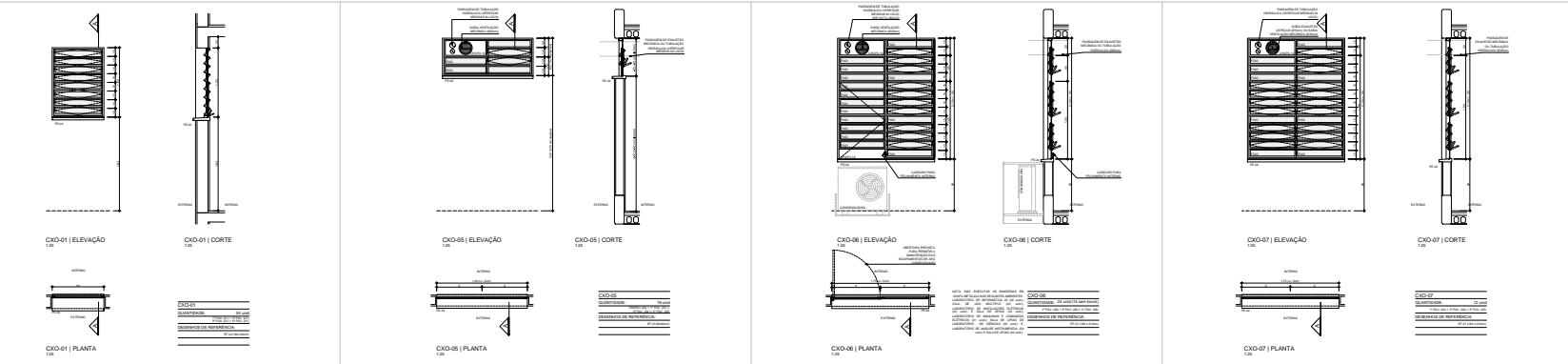
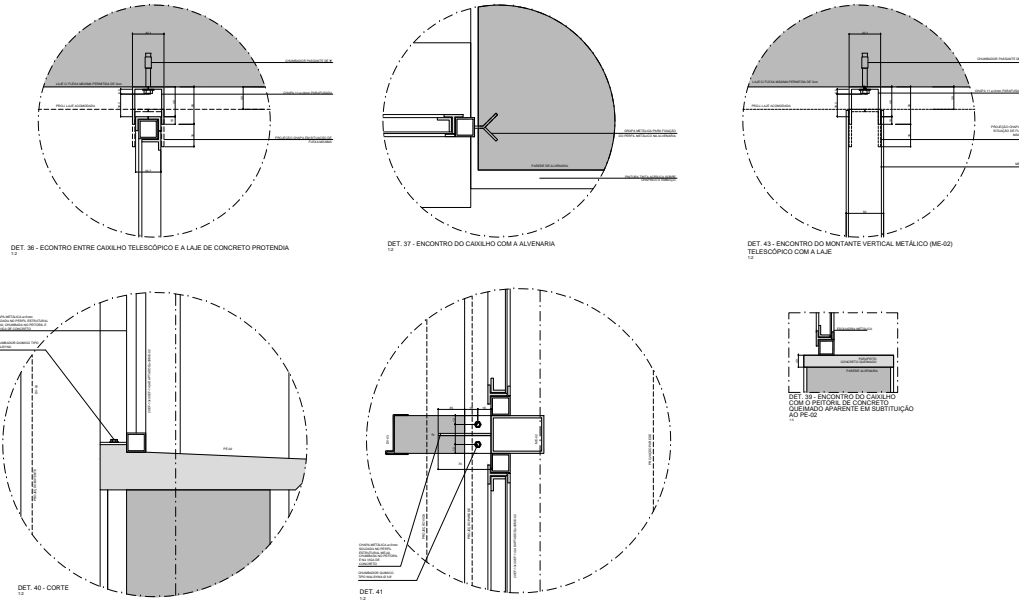

PROPOSTOR	UNIVERSIDADE FEDERAL DE SÃO CARLOS
PROJETADE	SONIA ATSUKO GOTO SUGAHARA
PROJETO	TERMINO DE OBRAS
LEGENDA	
PROPOSTOR	UNIVERSIDADE FEDERAL DE SÃO CARLOS
PROJETADE	SONIA ATSUKO GOTO SUGAHARA
PROJETO	TERMINO DE OBRAS
LEGENDA	
PROPOSTOR	UNIVERSIDADE FEDERAL DE SÃO CARLOS
PROJETADE	SONIA ATSUKO GOTO SUGAHARA
PROJETO	TERMINO DE OBRAS
LEGENDA	
PROPOSTOR	UNIVERSIDADE FEDERAL DE SÃO CARLOS
PROJETADE	SONIA ATSUKO GOTO SUGAHARA
PROJETO	TERMINO DE OBRAS
LEGENDA	



CEETEPSCAP2022249024A